

Sales Germany and other EU Countries

Naturschutzzentrum
Westlicher Hegau
Erwin-Dietrich-Str. 3
D-78244 Gottmadingen
Phone: 07731/977 103
Fax: 07731/977 104
e-mail: nsz.hegau@bund.net

Production and technical support:

Batec Hansueli Alder, Alpenstrasse 69
CH-8200 Schaffhausen
Electronic survey aids for field biology

Individual solutions in the fields of

- ✓ Video observation
- ✓ Event controlling with photoelectric beam technics
- ✓ Measuring and recording climatic data
- ✓ Data collecting and processing

Phone: +41 (0)52 317 43 40 - Fax: +41 (0)52 317 43 41
e-mail: hansueli.alder@batec.net

printed on 100% recycled paper

© Copyright 1995-2006 by Batec Hansueli Alder, CH-8200 Schaffhausen and SSF - Stiftung zum Schutze unserer Fledermäuse in der Schweiz, CH-8057 Zürich

SSF - Bat Detector



Ultrasound - superheterodyne receiver

- received frequency adjustable from 18kHz - 120 kHz
- with illumined frequency display
- robustly built, for everyday use in fieldwork
- integrated powerful loudspeaker
- electricity supply by 9V E-block battery
- 3,5 mm minijack for stereo headphones

3. Functioning Test

Having completed the circuit, check whether all the connections and cable connections are correct. Then you can test the functioning.

Proceed as follows:

- Turn the frequency controller (P1) on fully, to the maximum frequency of 120 kHz.
- Adjust the the volume controller (P2) to medium loudness.
- Switch off switch SW1 (push in direction of the battery compartment).
- Connect a 9 V battery to the battery clip.
- Turn on switch SW1 (direction of microphone)

Now you should be able to hear a slight hissing sound from the loudspeaker. This is the normal hissing sound that is produced by the receiver. In this case the Bat Detector has been assembled correctly. If you can hear a whistling tone or nothing at all there is a mistake in the circuit. Switch off the bat detector immediately to prevent any damage to the component parts. Check the wiring carefully and correct any possible mistakes. Should your Bat Detector not work even though everything is connected correctly send the appliance to our customer support (cf. box on opposite page).

R7	=	220 Ω	red-red-black-black
R8	=	10 k Ω	brown-black-black-red
R9	=	47 Ω	yellow-purple-black-gold
R10	=	1.5 k Ω	brown-green-black-brown
R11	=	8.2 k Ω	grey-red-black-brown
R12	=	8.2 k Ω	grey-red-black-brown
R13	=	22 k Ω	red-red-black-red
R14	=	100 Ω	brown-black-black-blac-
R15	=	3.6 k Ω	orange-blue-black-brown
R16	=	2.2 k Ω	red-red-black-brown
R17	=	5.6 k Ω	green-blue-black-brown
R18	=	330 k Ω	orange-orange-black-orange
R19	=	10 Ω	brown-black-black-gold

Now solder the wires carefully to the traces and cut them close to the soldered joint. **Keep one of the wires as you will need it later.**

1.2. Bases for the Integrated Circuits (IC)

To make the handling of the ICs easier, they are mounted on bases. Insert the base for IC1 (16 pins) and that for IC2 (8 pins) through the corresponding drillings in the circuit board. **The notches in the IC base must correspond to the printing on the circuit board.** If necessary, bend two diagonally opposed poles slightly from the reverse side to prevent the ICs from falling out. Now solder the poles carefully to the strip conductors.

1.3. MKT Capacitors

The values of the MKT capacitors are printed on their tops. Insert the capacitors according to the following table and bend the

Functioning

The SSF Bat Detector is an ultrasound receiver which functions according to the heterodyne principle and has been developed especially for detecting bats.

Their ultrasound orientation calls are received by the installed electret microphone and intensified by a highly sensitive preamplifier. Then the signal reaches the heterodyne IC, whose received frequency area can be externally adjusted. The receiver produces an AF Signal which contains the ultrasound sounds within the chosen frequency area as audible sounds. Finally this signal is amplified by the output transformer and reproduced through the installed loudspeaker or stereo headphones.

Technical Data

Model:	SSF - Bat Detector ultrasound-super heterodyne receiver
Frequency range:	18 - 120 kHz, adjustable
Output (max.):	0.25 Watt (via loudspeaker)
Headphones socket:	3.5 mm stereo mini jack (for portable stereo headphones)
Power supply:	9 Volt E-Block battery
Power consumption (typ.):	20 mA
Case:	robust plastic case (ABS), water resistant
Measurements:	158 x 85 x 47 mm (including Switches)
Weight (incl battery):	ca 200 g

We reserve the right to make changes that serve technical improvement without prior notice.

Layout Diagram

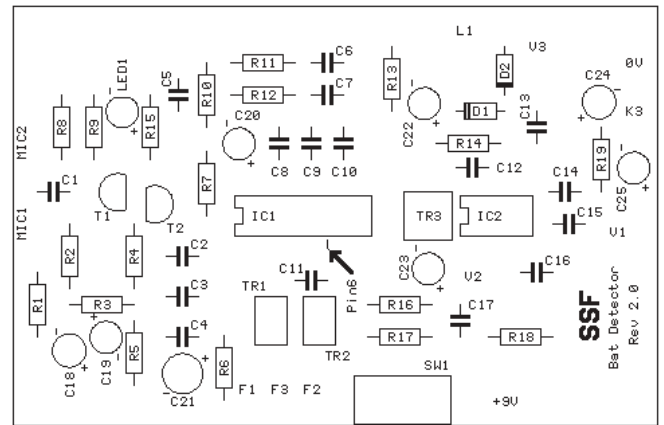

Connection Diagram

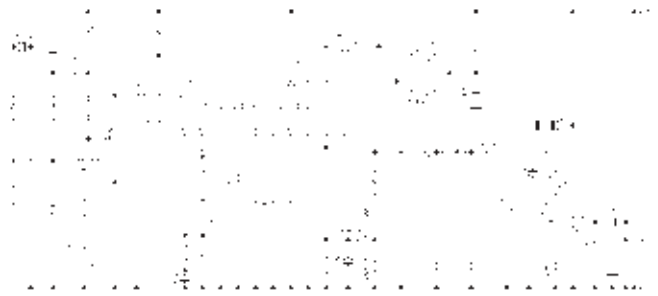

wires slightly to prevent them from falling out.

C1	=	1 nF	1n 100
C2	=	1 nF	1n 100
C3	=	680 nF	.68K50 or µ68K50
C4	=	680 nF	.68K50 or µ68K50
C5	=	33 nF	33nK100
C6	=	47 nF	47n 100
C7	=	47 nF	47n 100
C8	=	680 nF	.68K50 oder µ68K50
C9	=	680 nF	.68K50 or µ68K50
C10	=	680 nF	.68K50 or µ68K50
C11	=	1.5 nF	1500K400
C12	=	100 nF	.1n 63
C13	=	100 nF	.1n 63
C14	=	47 nF	47nK100
C15	=	100 nF	.1n 63
C16	=	1 nF	1n 100
C17	=	3.3 nF	3n3J100

Solder the capacitors to the traces and cut the wires close to the soldered joint.

1.4. Electrolytic Capacitors

The values of the cylindrical electrolytic capacitors are printed on their sides. The polarity of the wires is also marked there. The minus pole is marked with a white line with a minus sign. Take care to insert the condensators according to their correct polarity (+/-). The markings on the outside of the condensator must correspond to the printing on the circuit board. Push the condensators as far as possible onto the circuit board, esp. C21, and again, slightly bend the poles.

2.4.3. Fixing the Battery Clip

Solder the battery clip to the circuit board:

red cable to +9V
black cable to an 0V

To prevent the cable from tearing off when pulling the battery clip, make a knot in the cables and place it before the entry to the battery compartment. Take care that the cables in the battery compartment are still long enough so that the battery can be exchanged easily.

2.4.4. Inserting the Panel for the Slide Switch

Now insert the panel for the slide switch. The top of the slide switch SW1 should fit in the indentation on the panel. In case the switch jams when turned on or off, loosen the screws at the circuit board slightly and push them to the reverse side.

Connector Loudspeaker	Connector Minijack	Colour of cable
L1	K1	black
L2	K2	red
Minijack Socket	Circuit Board	
K3	K3	red
Loudspeaker	Circuit Board	
L1	L1	black

Soldering instructions

1. Only use resin cored solder with contents of 60% tin and 40% lead. Never use soldering fluid or soldering paste as they contain acid and can damage the components or the traces.

2. Keep the bit of the soldering iron always tidy so that you get neat soldering joints. Wipe off any superfluous solder tin or other residues on a damp sponge after each soldering.

3. Solder swiftly and let the soldering joint cool down a bit once during the process. If the soldering takes too long the traces might come off. It is especially important to keep the times given in the instruction when soldering heat sensitive components.

4. When soldering make sure that the bit of the soldering iron is sufficiently covered with solder tin and hold it so that the connection wire of the component and the trace on the printed board are both touched and heated at the same time. Then add a little solder and take it away again shortly after it starts melting; wait a little longer, until it has spread evenly and then take the soldering iron away from the soldering joint.

5. Make sure that the newly soldered part is not moved for at least five seconds. The result should be a perfect soldering joint, which surrounds the connection wire of the component and covers the trace on the printed circuit board well. If this is not the case please heat the soldering again and if necessary add a little more solder.

Guarantee and Technical Support

With the purchase of the SSF Bat Detector you have bought a high quality bat detector which will serve you for a long time. We guarantee the completeness of the assembly kit at purchase and give a one year guarantee for perfect functioning if the kit is assembled correctly. Please follow the assembly instructions exactly as otherwise we cannot grant full guarantee for your SSF Bat Detector.

Any damages caused by daily use, force or aging processes are not included in our guarantee.

Should your appliance not function properly we offer extensive technical support at minimum cost.

The use of the SSF Bat Detector is at your own risk and we are not liable for any damages caused in relation with the SSF Bat Detector.

If you have any questions concerning the SSF-Bat Detector please contact our technical support:

Batec
Hansueli Alder
Alpenstrasse 69
CH-8200 Schaffhausen

Fax: +41 (0)52 317 43 41
e-mail: hansueli.alder@batec.net

Important note sending parcels from outside Switzerland:
Notify „sending to repair“ on the customs declaration.

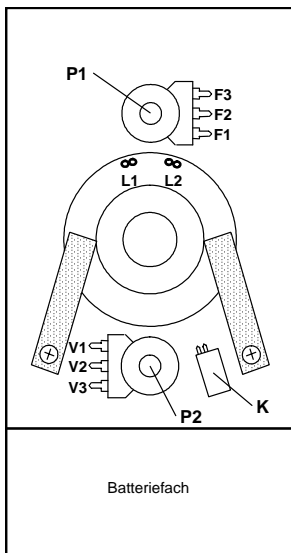

inside view of the case top

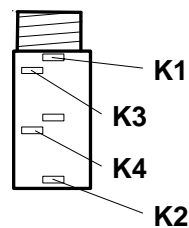

connections of the mini-jack (K)

Connection potentiometer	Connection circuit board	Colour of cable
F1	F1*	red
F2	F2*	green
F3	F3*	black
V1	V1	red
V2	V2	green
V3	V3	black

* Follow the markings on the connections exactly!

C18 =	470 μ F
C19 =	2.2 μ F
C20 =	47 μ F
C21 =	47 μ F
C22 =	10 μ F
C23 =	10 μ F
C24 =	470 μ F
C25 =	47 μ F

Make sure that the soldering process does not take longer than 10 seconds without interruption, as condensators are heat sensitive. Again, cut the poles level with the soldered joint.

1.5. Diodes

Pay attention to the polarity when inserting the two diodes. The ring mark on the diode must correspond to the marking on the circuit board.

D1 =	1N4148
D2 =	1N4148

Solder the diodes to the strip circuit and cut off the wires.

1.6. Slide Switch

Insert the slide switch SW1 so that the button points towards the edge of the circuit board. Bend the two outer poles slightly and solder all three poles to the traces.

Before you start...

Please read the instructions carefully before you start assembling the kit. Check whether your kit contains all the components listed in this instruction. Please notify the technical support if any components are missing.
If you have not assembled electronic assembly kits before, read the soldering instructions on page 22 carefully before you start.

Contents of the kit

The complete assembly kit should contain

- this instruction booklet
- a plastic bag containing the items you need for mounting the circuit board
 - one printed circuit board
 - the components listed in the various chapters of the following assembly
- the assembly kit for the case
- a set of rotary switches
- a set of loudspeakers and stereo headphones
- a set of cables

A few recommendations for practical use...

The frequency range of the Bat Detector enables you to receive the ultrasound cries of all European bats. The reproduction by the loudspeaker corresponds to the original sound. However, it is not possible to correctly determine the kind of bat only according to the frequency and the sound pattern, as the orientation calls of different kinds of bats can hardly be differentiated and can vary strongly even within the same species.

Therefore we decided not to give any lists of the various kinds of bats and their orientation cries but refer you to specialist literature on the subject.

We recommend unexperienced observers to go outside at dawn with the bat detector switched to 35-40 kHz. The calls of many European species of bats can be received within this frequency area and the chances are good that you will hear your first bat and soon also see it. From time to time it might also be worth while trying the whole frequency area.

If you cannot detect any bats near your own home try finding them near forests and rivers or lakes.

1.7. Trimmers

Insert the blue, 3-poled potentiometers in the corresponding holes, bend the poles TR1 and TR2 apart slightly.

TR1	=	100 k Ω	100K
TR2	=	4.7 k Ω	4K7
TR3	=	2.5 k Ω	2K5

Solder the potentiometer neatly onto the circuit board and cut the poles level with the soldered joints.

1.8. Transistors

The transistors are inserted according to the printing on the circuit board. There should be a distance of 4 to 5 mm between the transistor and the circuit board.

T1	=	BC548C	C548C
T2	=	BC558C	BC558C

Now solder the transistors to the traces and cut the poles close to the soldered joints. **Note: The soldering must not take longer than 5 sec. If necessary solder several times. Transistors are heat sensitive.**

1.9. Soldering Lugs

Now only the soldering lugs are left. They are needed for the cable connections to the loudspeaker, the headphones and the battery. Insert the forked soldering lugs into the remaining 12 drillings and solder them well to the traces using sufficient solder.

Proceed in the same way with the cables of the microphone that are in the case set.
Always make sure that the soldered connections are sufficiently covered with solder.

2.4.1. Connecting the Microphone

Solder the cables of the microphone to the soldering tags on the circuit board as follows:

red cable to MIC1
black cable to MIC2

Now the circuit board can be fixed to the bottom part of the case with the 6,5 mm screws and the front panel can be inserted in the slot in the bottom part.

2.4.2. Remaining Cable Connections

The remaining 10 cm-cables are used for connecting various components of the case with the printed board and among each other. (Cf. table on page 16 and 17).
The markings of the connections are either given in the table on p. 15 or printed on the circuit board. When all the cables are connected correctly the mini-jack can be inserted in the case lid (cf. table p. 16). Enlarge the holes if necessary with a nail punch.

- Turn the frequency switch left, to the minimum frequency of 18 kHz.
- With the screw at the trimming potentiometer TR1 set its frequency to 18 kHz.

You should hear on the loudspeaker, if you strike two metal items together (keys would serve well in this case).

If the volume is too low when the volume control is turned to maximum, turn the resistor TR3 clockwise until the desired volume is reached (turning it too far will cause feedback interference). If everything functions well, you can screw the parts of the case together using the four 18mm screws. Be careful not to jam any cables between the two parts of the case.

Some remarks about using the Bat Detector...

The Bat Detector is designed to be maintenance free. However, a few directions which are essential for flawless functioning should be observed.

- Only use alkaline or lithium batteries that will not leak, or (only for very frequent use) rechargeable batteries.
- Only use stereo headphones.
- Protect the appliance from heat or damp. If water gets into the case open it and let it dry out completely.
- Never use solvents for cleaning the case as they might damage the finish. Use a damp cloth to clean the case.

Should you have any problems with your bat detector our technical support will be glad to help you (address on p. 3).

Tools you need

You will also need the following tools which are not contained in the kit:

- a soldering iron, 15-30 Watt or soldering appliance with a working temperature of 320-350°C
- resin cored solder (60% tin, 40% lead)
- a Philips® screw driver (medium size)
- a screw driver (size 0)
- a spanner (10 mm)
- a wire stripper or a small knife
- a wire cutter
- an alkaline battery 9V E-Block
- a frequency indicator (10 to 150 kHz) *
- a small pair of pliers
- some stranded wire used for unsoldering

* The frequency indicator will only be needed at the very end. You will still be able to assemble the complete kit even if you do not have access to a frequency indicator. In this case please refer to page 19.

2.2. Assembling the Loudspeakers

The compact loudspeaker is fixed against the case lid with the clamps (cf. drawing next page). The necessary components are in the loudspeaker set.

- Fix the clamps to the case using the two 6.5 mm screws. If necessary, the drillings in the clamps have to be rough-cut with the screw or widened with a drill to 3mm.

2.3. Preparing the Socket for the Headphones

To make the sound audible on both channels of the headphones the connections K3 and K4 of the socket have to be linked (see plan next page).

- First cover all the connections of the mini-jack with solder.
- Now take the piece of wire that was kept when inserting the resistors and solder it to the connections K3 and K4. **Tale care that the wire does not touch any of the other connections.**

2.4. Cable Connections

Now the various cable connections have to be set up. First cover the soldering lugs on the circuit board as well as the soldering tags of the potentiometers and of the loudspeakers with solder.

Take the cable from the cable set and cut off 3mm of the insulation at the end of each cable with a wire stripper or a knife. Drill the blank wires together and cover them with solder. Proceed in the same way with the cables of the microphone that are in the case set.

Always make sure that the soldered connections are sufficiently covered with solder.

1.10. Mounting of the LED

Solder the light diode (LED 1) for illumination of the frequency dial. Be sure to note the correct polarity: the longer lead is positive (+). To insure that the diode fits properly in the casing, insert it so that the longer lead (+) extends exactly 1.3 cm from the back of the plate. The LED should be perpendicular to the plate. Bend the leads to the side, solder them and cut off the extra length.

1.11. Mounting of the ICs

Mount IC1 and IC2 carefully on the base. Take care that the notches on the ICs correspond to the notches on the bases and that the poles are not bent.

IC1 = TCA440 oder A244D (16poles)
IC2 = LM386N-1 (8poles)

Important!

Check the position of the components carefully against the plan on page 23. Also check the soldered connections and make sure that the poles of the components are completely covered by solder and well connected to the traces. If necessary, solder again. The detector will function perfectly only if all components are well connected to the printed circuit.

Assembling the SSF-Bat Detector

1. Insertion of Components onto the Circuit Board

All components you need are in the plastic bag labelled "Bauteile für die Leiterplattenmontage" (Components for assembling the circuit board). The white printing on one side of the circuit board shows you where the components have to be inserted. **Insert all the components from this side.** On the reverse side of the circuit board are the traces which are covered with a green layer except for the parts where the components have to be soldered on.

1.1. Resistors

The resistors are marked with colour rings which indicate the value of the resistor. Bend the legs of the resistor in a 90° angle so that they fit through the drillings, and insert them at the marked spaces according to the table below. Make sure that they lie on the circuit board and bend the wires on the reverse side in an 45° angle to prevent them from falling out.

Note: The table gives only the first four colour rings of the resistor which indicate its actual value. Depending on the producer there may be one or two more colour rings that are not important here.

R1	=	15 kΩ	brown-green-black-red
R2	=	39 kΩ	orange-white-black-red
R3	=	39 kΩ	orange-white-black-red
R4	=	6.8 kΩ	blue-grey-black-brown
R5	=	4.7 kΩ	yellow-purple-black-brown
R6	=	470 Ω	yellow-purple-black-black

4. Adjusting the Border Frequencies

Finally the upper and lower border frequencies have to be adjusted. For this you need a frequency counter which covers the area from 15 to 125 kHz.

If you do not have access to a frequency counter or if your assembled bat detector does not function please use our free technical support. Send the assembled device in the original box together with €10 in cash and a self-addressed label to our technical support department (address on page 3).. We will return your bat detector ready for use within a few days.

Adjust the border frequencies as follows:

- Turn the frequency control right, to the maximum frequency of 120 kHz.
- Connect the ground (GND) of the frequency counter to the OV connection on the printed circuit board.
- Connect the signal input of the frequency counter to the 6. pin of IC 1 (marked on the circuit board with pin6). Pay attention that the adjoining pins are not touched.
- Switch the bat detector on (switch SW1).
- Set the frequency with the screw at the trimming potentiometer TR2 so that the frequency counter shows 120 kHz (turn clockwise to increase frequency and counterclockwise to decrease it).

2. Assembly of the Case

To make assembling the case easier for you the parts are packed in different units:

- The case set, including
 - the case lid with labels showing the volume and frequency scales
 - bottom part of the case with name plate
 - lid for the battery compartment
 - front panel with in-built microphone
 - panel for the slide switch
 - 4 screws, 18 mm, for screwing the case together
 - 4 screws, 6.5 mm, for fixing the circuit board inside the case
- The control box set, including
 - 2 potentiometers with 6 mm shaft, 10 kΩ and 22 kΩ
 - 2 nuts
 - 1 number disc
 - 1 arrow disc
 - 2 knurled knobs
 - 2 caps (1 red, 1 black) for knurled knobs
- The loudspeaker/headphones set, including
 - compact loudspeaker 0.25 W
 - 2 clamps
 - 2 screws, 6.5 mm
 - stereo minijack socket
- The cable set, including
 - connection cable with 9 Volt battery clip
 - 4 black cables (length: 10 cm)
 - 4 red cables (length: 10 cm)
 - 2 green cables (length: 10 cm)

2.1. Assembling the Frequency and Volume Controls

First take the case lid from the case set. All the other components you need are in the control switches set. Assemble the two rotary potentiometers P1 and P2 according to the drawing shown on page 15.

P1	=	22kΩ	22K A	The labelling ist printed on the
P2	=	10kΩ	10K A	side of the potentiometers.

Proceed as follows:

- Push the potentiometer through the corresponding hole in the casing so that the shaft protrudes from the upper surface.
- Screw the potentiometer in place with the nut, paying attention to the position of the soldered connections.
- Shorten the black plastic shaft of the potentiometer to 4 mm with the wire clippers.
- Position the numbered disc and the arrow disc beneath the knurled knobs.
- Place the knobs on the shafts of the potentiometers and clamp them with the nuts. Be sure that the discs are in the right position before tightening.
- Place the caps on the potentiometer knobs: red for P1, black for P2.